

Dye-sensitized Solar Cell Structure Suitable for High Power Module

Ichiro Gonda*, Yasuo Okuyama*, Junya Takashima* and Keizo Furusaki*, Satoshi Uchida**
 *R&D Center NGK SPARK PLUG CO., LTD
 2808 Iwasaki, Komaki, Aichi, 485-8510, Japan
 **IMRAM, Tohoku Univ.

1-1, Katahira 2-chome, Aoba-ku, Sendai, 980-8577, Japan

Introduction

Dye-sensitized solar cell (DSSC) draw a quite attention to meet future solar energy market demanding low cost photovoltaic devices, because the manufacturing process is relatively simple.

Since a single cell of DSSC generates only the low voltage not more than 0.7V, and it is necessary to make an in-series connection of cells to obtain much higher voltage for practical application. The problem here is that the conventional structure of DSSC comprises two substrates that have one electrode on each (Fig. 1), and to make an in-series connection of cells; the connecting structure would be complicated as much as fabrication process of the high power DSSC module, and may lose advantage of the simple manufacturing process mentioned earlier.

To maintain the simple DSSC module structure, we have developed the monolithic structure by adapting the fine lithography of our microprocessor technology on ceramic substrates as the same technique as our ceramic microprocessor packages.

As shown in Fig. 2, the newly designed cell is formed on a single plane of a ceramic substrate and screen printed a pair of interdigitated tungsten electrodes; which have excellent tolerance against I_3^-/I^- electrolyte, with line and space less than 100 micrometers.

Followings are advantages of this configuration.

- Simpler DSSC module fabrication by simultaneous formation of pair electrodes on a substrate.
- The electrical resistance of fine printed interdigitated electrodes is pretty low enough for a large scale DSSC.
- As shown in Fig. 3, the newly designed structure can easily obtain the voltage that required by in-series connection, and can also obtain larger current by lengthening the arrays of interdigitated electrodes.
- By forming another dye-sensitized TiO_2 layer on conducting glass as third electrode, a tandem structure in a single compartment can be easily realized; which contributes further more efficient light harvesting.

Experimental

In Fig. 4, a typical cell structure is explained.

1. A pair of tungsten interdigitated electrodes of 50-100 micrometers width and 50-100 micrometers gap were screen-printed on an Al_2O_3 substrate and co-fired.
2. Pt catalytic layers of 200 nanometers were formed on one of the electrodes.
3. On the other electrode, TiO_2 layers, which average particle diameter is about 20 nanometers, were formed, and immersed into dye solution for 24 hours.
4. Polymer sealant gel was screen-printed on the edge of the substrate, and was solidified by heat-treatment after glass was stuck onto the substrate.
5. Liquid electrolyte is impregnated through small holes on the substrate, and sealed by polymer sealant.

Result and Discussion

The cell worked quite efficiently as much as DSSC module is expected. Details will be presented at the conference.

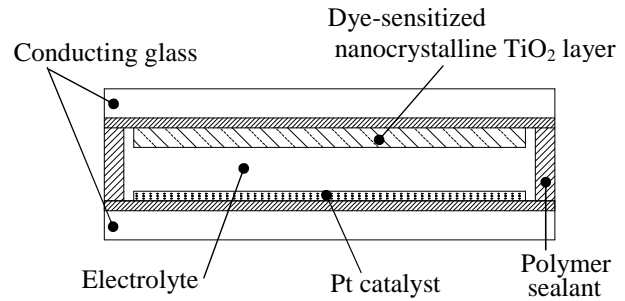

Fig. 1 Cross section of a conventional dye-sensitized solar cell

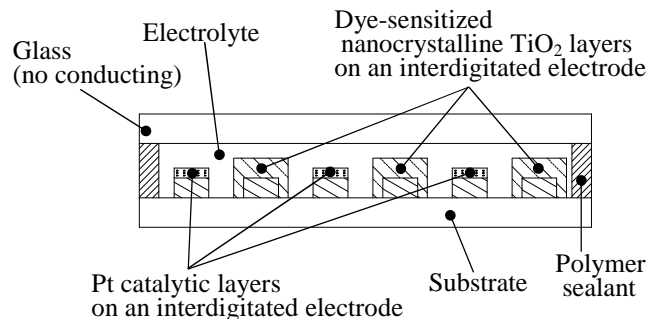

Fig. 2 Cross section of the newly designed cell structure

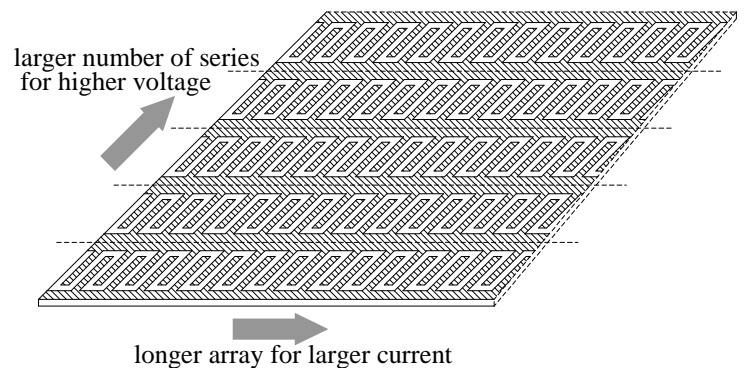

Fig. 3 Module substrate for the newly designed cell structure

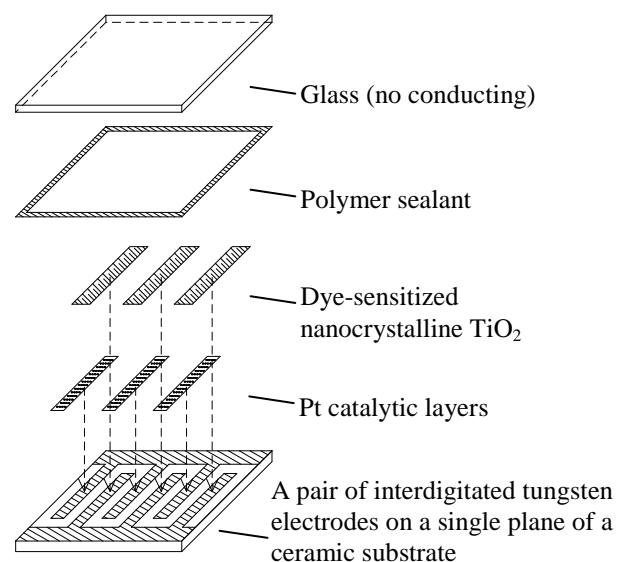

Fig. 4 Example of the newly designed cell structure